



PRODUCT BULLETIN

Break-away Switch

DESCRIPTION

The DEWEL Break-away Switch is designed to energize a towed trailer brake in the event of unintended decoupling of the trailer from the towing vehicle. When in normal operation, the Break-away Switch operates as a normally open switch between the stored energy source (the battery) on the trailer and the trailer brake system. In the event of unintended decoupling of the trailer from the towing vehicle, a pin is pulled which activates the switch. Activating the switch allows electrical power to be connected to the trailer brake system. In some cases, the switch directly connects a trailer battery to the electromagnetic coils of the electric brakes.

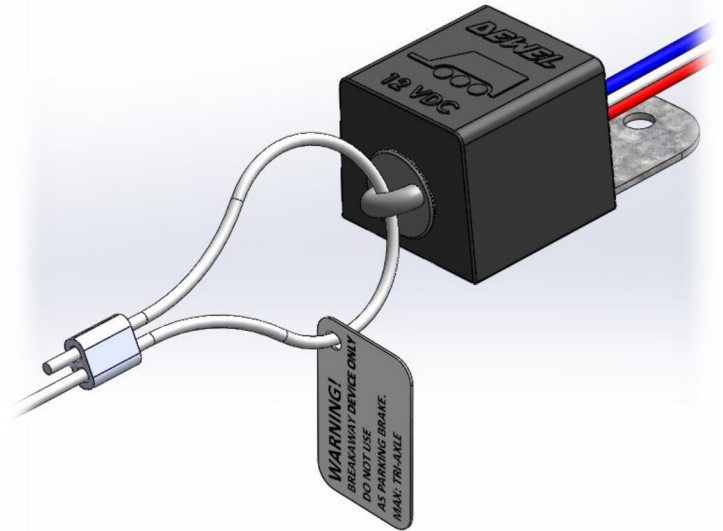

BENEFITS

- Long Life — No contacts to corrode or short.
- Waterproof design allows switch to be submersed and pressure washed while connected to power source.
- LED Test Light—Verifies power to the trailer brakes.

SPECIFICATIONS

Supply Voltage	12 Vdc
Rated Current	30 Amps for 3 Axle Trailers
Operating Temperature.....	-40 °F to 185 °F -40 °C to 85 °C
Storage Temperature:	-67 °F to 311 °F -55 °C to 125 °C
Degree of Protection	IP69K

This document is intended to provide general information about DEWEL products. DEWEL has attempted to present accurate information about DEWEL products in its brochures, catalogs, product bulletins, and other printed materials. DEWEL is not responsible for errors, inaccuracies or inconsistencies that may exist in any of its printed materials or any damages arising from or related to reliance on information in them. Materials and specifications for DEWEL products provided in catalogs, brochures, and other printed materials are subject to change without notice or obligation. Refer to www.dewelcontrols.com for the most recent versions of our literature.

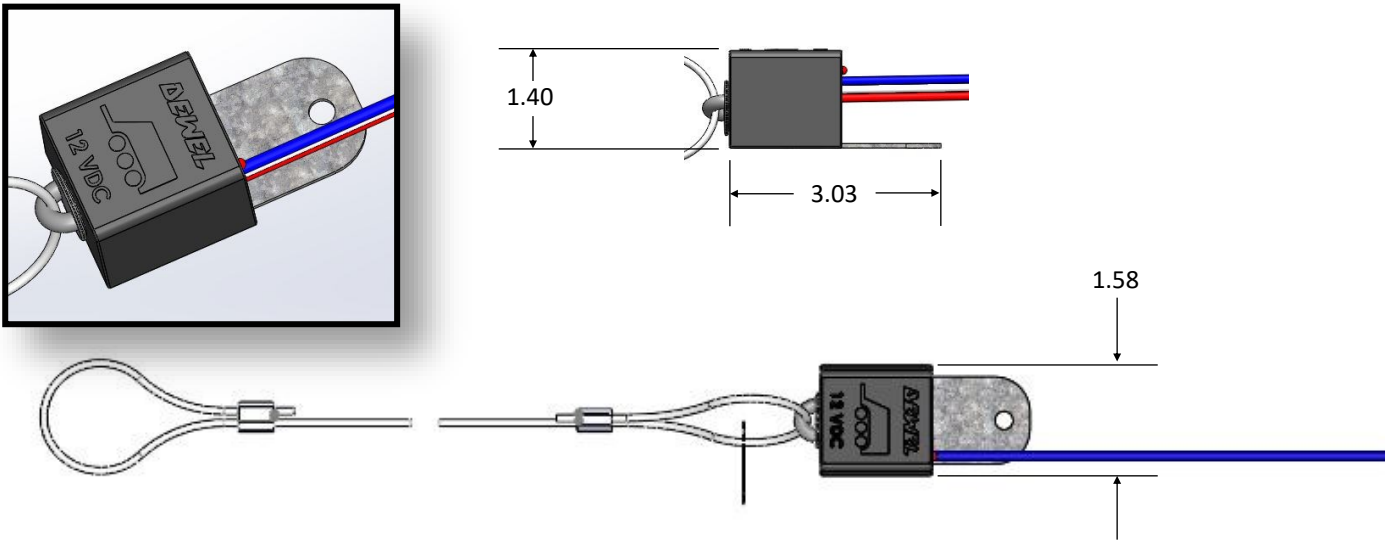

Dimensions are in inches.

Standard Cable Length: 48". Wire: 14 Gauge. Wire length options: 7", 24" or 48". Mounting hole for 1/4" bolt.

SCHEMATIC WIRING DIAGRAM FOR BREAK-AWAY SWITCH

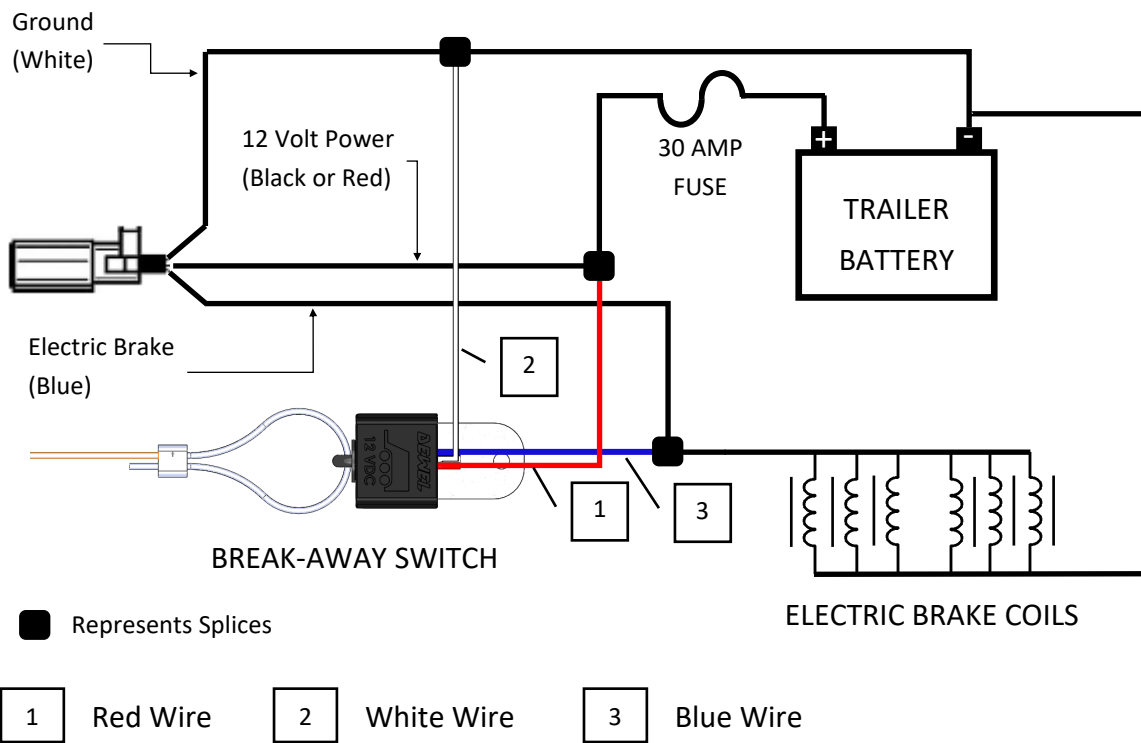

For more information see **EP16001-300 BREAK-AWAY SWITCH INSTALLATION INSTRUCTIONS**



Dewel, LLC

149 Fairway Dr.

Mankato, MN USA 56001-3139

Tel: +1 507 720 5720 Fax: +1 507 344 1833

www.dewelcontrols.com